

17. CANADA

CONTENTS

ITEM	PAGE
17.1 Standards Organizations	
17.1.1 CSA	276
17.1.2 SCC	278
17.2 Cable Types	
17.2 Cable Types	279
17.3 Supply Voltage and Plug Configurations	
17.3 Supply Voltage and Plug Configurations	287
17.4 Fire Ratings	
17.4.1 "FT1" Fire Test	288
17.4.2 "FT4" Fire Test	288
17.4.3 "FT6" Fire Test	288



17. CANADA

17.1 Standards Organizations

17.1.1 CSA

Canadian Standards Association
178 Rexdale Boulevard
Rexdale, Ontario M9W1R3
Canada
Tel: 416-744-4000

DOCUMENT NO.	TITLE
C22.1	Canadian Electrical Code, Part 1
C22.2 No. 0	General Requirements—Canadian Electrical Code, Part 2
C22.2 No. 0.3	Test Methods for Electrical Wire and Cables
C22.2 No. 0.6	Flammability Testing of Polymeric Materials
C22.2 No. 0.7	Equipment Electrically Connected to a Telecommunication Network
C22.2 No. 0.8	Safety Functions Incorporating Electronic Technology
C22.2 No. 0.11	Classification of Polymeric Compounds
C22.2 No. 0.12	Wiring Space and Wire Bending Space in Enclosures for Equipment Rated 750 V or Less
C22.2 No. 16	Insulated Conductors for Power-Operated Electronic Devices
C22.2 No. 17	Cable for Luminous-Tube Signs and for Oil and Gas-Burner Ignition Equipment
C22.2 No. 18	Outlet Boxes, Conduit Boxes, and Fittings
C22.2 No. 21	Cord Sets and Power Supply Cords
C22.2 No. 26	Wireways, Auxiliary Gutters, and Associated Fittings
C22.2 No. 35	Extra-Low-Voltage Control Circuit Cables, Low-Energy Control Cable, and Extra-Low-Voltage Control Cable
C22.2 No. 38	Thermoset-Insulated Wires and Cables
C22.2 No. 41	Grounding and Bonding Equipment
C22.2 No. 42	General Use Receptacles, Attachment Plugs, and Similar Wiring Devices
C22.2 No. 48	Nonmetallic Sheathed Cable
C22.2 No. 49	Flexible Cords and Cables
C22.2 No. 51	Armored Cables
C22.2 No. 52	Service-Entrance Cables
C22.2 No. 56	Flexible Metal Conduit and Liquid-Tight Flexible Metal Conduit
C22.2 No. 62	Surface Raceways and Lighting Fixture Raceways and Fittings
C22.2 No. 65	Wire Connectors
C22.2 No. 75	Thermoplastic-Insulated Wires and Cables
C22.2 No. 96	Portable Power Cables
C22.2 No. 116	Coil-Lead Wires

Continued

17.1.1 CSA

**Canadian Standards Association
178 Rexdale Boulevard
Rexdale, Ontario M9W1R3
Canada
Tel: 416-744-4000**

Continued

DOCUMENT NO.	TITLE
C22.2 No. 123	Aluminum-Sheathed Cables
C22.2 No. 124	Mineral-Insulated Cable
C22.2 No. 126	Cabletroughs and Fittings
C22.2 No. 127	Equipment Wires
C22.2 No. 129	Neutral Supported Cable
C22.2 No. 130	Heating Cables and Heating Cable Sets
C22.2 No. 131	Type TECK 90 Cable
C22.2 No. 138	Heat Tracing Cable and Cable Sets for Use in Hazardous Locations
C22.2 No. 174	Cables and Cable Glands for Use in Hazardous Locations
C22.2 No. 179	Airport Series Lighting Cables
C22.2 No. 188	Splicing Wire and Cable Connectors
C22.2 No. 197	PVC Insulating Tape
C22.2 No. 198	Underground Cable Splicing Kits
C22.2 No. 208	Fire Alarm and Signal Cable
C22.2 No. 210	Appliance Wiring Material Products
C22.2 No. 211	Rigid PVC (Unplasticized) Conduit
C22.2 No. 214	Communications Cables
C22.2 No. 222	Type FCC Under-Carpet Wiring Systems
C22.2 No. 230	Tray Cables
C22.2 No. 232	Optical Fiber Cables
C22.2 No. 239	Control and Instrumentation Cables
C49.1	Round Wire, Concentric-Lay, Overhead Electrical Conductors
C49.2	Compact Aluminum Conductors Steel Reinforced (ACSR)
C49.3	Aluminum Alloy 1350 Round Wire, All Tempers for Electrical Purposes
C49.4	Concentric-Lay Aluminum-Stranded Conductors (ACSC)
C49.5	Compact Round Concentric-Lay Aluminum-Stranded Conductors (Compact ACSC)
C49.6	Zinc-Coated Steel Wires for Use in Overhead Electrical Conductors
C49.7	Aluminum Round Wires for Use in Overhead Electrical Conductors
C57	Electrical Power Connectors for use in Overhead Line Conductors
C68.1	Paper-Insulated Power Cable
C68.2	Concentric Neutral Power Cable

Continued

17. CANADA

**CSA
Canadian Standards Association
178 Rexdale Boulevard
Rexdale, Ontario M9W1R3
Canada
Tel: 416-744-4000**

Continued

DOCUMENT NO.	TITLE
C68.3	Power Cable with Thermoset Insulation
C68.4	Portable Power Cable
C83	Communication and Power Line Hardware
C170.2	Polyethylene Protective Covering on Paper-Insulated Metallic-Sheathed Power Cable
C170.3	Polyvinyl-Chloride (PVC) Protective Covering on Paper-Insulated Metallic-Sheathed Power Cable
Z243.12.2	Data Communication-15 Pin DTE/DCE Interface Connector and Pin Assignments

**17.1.2 SCC
Standards Council of Canada
350 Sparks Street
Suite 1203
Ottawa, Ontario K1R 7S0
Canada
Tel: 613-238-3222
Fax: 613-995-4564**

17.2 Cable Types

Table 17.1—Some Canadian cable types, conditions of use and maximum conductor temperatures

Conditions of Use	Trade Designation	CSA Type Designation	Maximum Allowable Conductor Temperature
			°C
For exposed wiring in dry locations only	Armored Cable	TECK90	90
		AC90	90
For exposed wiring in dry locations where exposed to corrosive action, if suitable for corrosive conditions encountered	Armored Cable	TECK90	90
For exposed wiring in dry locations where not exposed to mechanical injury	Nonmetallic Sheathed Cable	NMD90	90
For exposed wiring in dry locations and in Category 1 and 2 locations, where not exposed to mechanical injury	Nonmetallic Sheathed Cable	NMW, NMWU	60
For exposed wiring in dry or damp locations	Rubber- (Thermoset-) Insulated Cable	R90	90
	Thermoplastic-Insulated Cable	TW	60
	Nylon Jacketed Thermoplastic-Insulated Cable	T90 NYLON	90
	Nonmetallic Sheathed Cable	NMD90	90

Continued

17. CANADA

Table 17.1—Some Canadian cable types, conditions of use and maximum conductor temperatures

Continued

Conditions of Use	Trade Designation	CSA Type Designation	Maximum Allowable Conductor Temperature
			°C
For exposed wiring in wet locations	Armored Cable	TECK90	90
		ACWU90	90
	Rubber- (Thermoset-) Insulated Cable	RW75	75
		RL90, RW90	90
	Aluminum-Sheathed Cable	RA75	75
		RA90	90
Mineral-Insulated Cable	MI, LWMI	90	
Thermoplastic-Insulated Cable	TW	60	
	TW 75	75	
Nonmetallic Sheathed Cable	NMWU	60	
For exposed wiring where exposed to the weather	Armored Cable	TECK90	90
		RW75	75
	Rubber- (Thermoset-) Insulated Cable	R90, RW90	90
		Thermoplastic-Insulated Cable	TW, TWU
		TWU75	75
Neutral-Supported Cable	NS-1, NSF-2	75	
Nonmetallic Sheathed Cable	NMWU	60	
For concealed wiring, dry locations only	Armored Cable	TECK90	90
		AC90	90
For concealed wiring, dry and damp locations	Nonmetallic Sheathed Cable	NMD90	90
For concealed wiring in dry locations and in Category 1 and 2 locations where not exposed to mechanical injury	Nonmetallic Sheathed Cable	NMW, NMWU	60

Continued

Table 17.1—Some Canadian cable types, conditions of use and maximum conductor temperatures

Continued

Conditions of Use	Trade Designation	CSA Type Designation	Maximum Allowable Conductor Temperature
			°C
For concealed wiring in wet locations	Armored Cable	TECK90	90
		ACWU90	90
	Nonmetallic Sheathed Cable	NMWU	60
	Aluminum-Sheathed Cable	RA75	75
RA90		90	
	Mineral-Insulated Cable	MI, LWMI	90
For use in raceways, except cable trays, in dry or damp locations	Rubber- (Thermoset-) Insulated Cable	R90	90
		Thermoplastic-Insulated Cable	TW
	Nylon Jacketed Thermoplastic-Insulated Cable	T90 NYLON	90
For use in raceways, except cable trays, in wet locations	Rubber- (Thermoset-) Insulated Cable	RW75, RWU75	75
		RW90, RWU90	90
	Thermoplastic-Insulated Cable	TW, TWU TW75, TWU75	60 75
For use in ventilated, nonventilated and ladder type cable trays in dry locations only	Armored Cable	AC90	90
		TECK90	90
For use in ventilated, nonventilated and ladder type cable trays in wet locations	Armored Cable	TECK90	90
		ACWU90	90
	Aluminum-Sheathed Cable	RA75	75
		RA90	90
Mineral-Insulated Cable	MI, LWMI	90	
Rubber- (Thermoset-) Insulated Lead-Sheathed Cable	RL90	90	

Continued

17. CANADA

Table 17.1—Some Canadian cable types, conditions of use and maximum conductor temperatures

Continued

Conditions of Use	Trade Designation	CSA Type Designation	Maximum Allowable Conductor Temperature
			°C
For use in ventilated and nonventilated cable trays in vaults and switch rooms	Rubber- (Thermoset-) Insulated Cable	RW75	75
		RW90	90
For direct earth burial (with protection as required by inspection authority)	Armored Cable	ACWU90	90
		TECK90	90
	Nonmetallic Sheathed Cable	NMWU	60
		Rubber- (Thermoset-) Insulated Cable	RWU75 RL90, RWU90
Aluminum-Sheathed Cable	RA75	75	
	RA90	90	
For direct earth burial (with protection as required by inspection authority)	Mineral-Insulated Cable	MI, LWMI	90
	Thermoplastic-Insulated Cable	TWU	60
		TWU75	75
Airport series lighting cable	ASLC	90	
For service entrance above ground	Armored Cable	AC90	90
		ACWU90	90
		TECK90	90
	Aluminum-Sheathed Cable	RA75	75
		RA90	90
	Mineral-Insulated Cable	MI	90
Neutral Supported Cable	NS-1	75	
	NSF-2		

Continued

Table 17.1—Some Canadian cable types, conditions of use and maximum conductor temperatures

Continued

Conditions of Use	Trade Designation	CSA Type Designation	Maximum Allowable Conductor Temperature
			°C
For service entrance below ground	Service-Entrance Cable	USEI90	90
		USEB90	90
	Thermoplastic Insulated Wire	TWU	60
		TWU75	75
	Rubber- (Thermoset-) Insulated Cable	RWU75	75
		RWU90	90
Armored Cable	TECK90	90	
	ACWU90	90	
Aluminum-Sheathed Cable	RA75	75	
	RA90	90	
For high-voltage wiring in luminous-tube signs	Luminous-Tube Sign Cable	GTO, GTOL	60
For use in raceways in hoistways	Hoistway Cable	—	60
For use in Class 2 circuits, in exposed or concealed wiring or use in raceways, in dry or damp locations	Extra-Low-Voltage Control Cable	LVT	60
For use in Class 2 circuits in dry locations in concealed wiring or exposed wiring where not subject to mechanical injury	Extra-Low-Voltage Control Cable	ELC	60
For use when concealed indoors under carpet squares, in dry or damp locations	Flat Conductor Cable	FCC	60

Continued

17. CANADA

Table 17.1—Some Canadian cable types, conditions of use and maximum conductor temperatures

Continued

Conditions of Use	Trade Designation	CSA Type Designation	Maximum Allowable Conductor Temperature
			°C
For use in communication circuits when exposed, concealed or used in raceways, indoors in dry or damp locations, or in ceiling air handling plenums	Inside Wiring Cable	IWC	60
	Z Station Wire	ZSW	60
	Premise Communication Cable	PCC	60
	Communication Cable	MPP, CMP, MPR, CMR, MPG, CMG, MP, CM, CMX, CMH	60
For use in communication and community antenna distribution circuits when exposed, concealed or used in raceways, indoors in dry or damp locations or in plenums	Coaxial Cable	CXC	60
For use in communication circuits, when exposed, concealed, or used in raceways, in dry or damp locations, within and between buildings	Communication Building Cable	CBC	60
For use in communication circuits when concealed indoors under carpet squares, in dry or damp locations	Communication Flat Cable	CFC	60

Continued

Table 17.1—Some Canadian cable types, conditions of use and maximum conductor temperatures

Continued

Conditions of Use	Trade Designation	CSA Type Designation	Maximum Allowable Conductor Temperature
			°C
For use in communication circuits when exposed, concealed or used in raceways, indoors in dry or damp locations, or in ceiling air handling plenums	Flame and Smoke Tested Cable	FSTC	60
For use in fire alarm, signal and voice communication circuits where exposed, concealed or used in raceways, indoors in dry or damp locations	Fire Alarm and Signal Cable	FAS FAS 90 FAS 105 FAS 200	60 90 105 200
For use in raceways including ventilated, nonventilated and ladder type cable trays in wet locations and where exposed to weather	Tray Cable	TC	As marked on cable.
For use in cable trays in Class I Division 2 and Class II Division 2 hazardous locations	Tray Cable	TC	As marked on cable.
For use in buildings in dry or damp locations, where exposed, concealed or used in raceways, or in plenums	Nonconductive Optical Fiber Cable	OFNP, OFNR, OFNG, OFN, OFNH	60 (higher if so marked on cable)

Continued

17. CANADA

Table 17.1—Some Canadian cable types, conditions of use and maximum conductor temperatures

Continued

Conditions of Use	Trade Designation	CSA Type Designation	Maximum Allowable Conductor Temperature
			°C
For use in buildings in dry or damp locations, where exposed, concealed or used in raceways, or in plenums	Conductive Optical Fiber Cable	OFCP, OFCR, OFCG, OFC, OFCH	60 (higher if so marked on cable)
For use in buildings in dry or damp locations, where exposed or concealed	Hybrid Conductor Cable	NMDH90	90

Source: CSA C22.1



17.3 Supply Voltage and Plug Configurations

Table 17.2–Canadian supply voltage

FREQUENCY (Hz)	VOLTAGE
60	120/240

The neutral wire of the secondary distribution system is grounded. Three-phase, 4-wire systems such as 120/208 volts are available as well as 347/600 volts for commercial establishments.

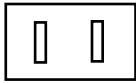
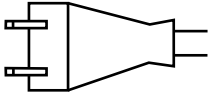
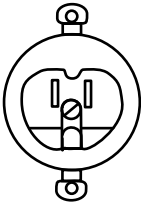
Table 17.3–Canadian plug configurations

Jack	Plug	Description
		North American Ungrounded
		North American NEMA 5-15

17. CANADA

17.4 Fire Ratings

The Canadian Electrical Code, published by the Canadian Standards Association, is the national safety code for electrical installations that is adopted into law by each province and territory with amendments or local rules. The Code includes references to a stringent series of tests developed for flame testing of wires and cables. Cables are marked from “FT1” to “FT6,” depending on which of the specified flame test requirements they fulfill.

17.4.1 “FT1” Fire Test

The FT1 test procedure is known as the “Vertical Test” (published in CSA Standard C22.2 No. 0.3 Test Methods for Electrical Wires and Cables, para 4.11.1).

Cables are subjected to five, 15 second duration applications of a specified flame. For the cable to pass the test, burning must cease within 60 seconds after removal of the flame source, and not more than 25% of the extended portion of the indicator can be burned.

17.4.2 “FT4” Fire Test

The FT4 test procedure is known as the Vertical Flame Test — Cables in trays (published in CSA Standard C22.2 No. 0.3 Test Methods for Electrical Wires and Cables, para 4.11.4).

Cables are mounted on a vertical tray and exposed for 20 minutes to a 70,000 BTU/hr flame. For the cable to pass the test, the resulting char distance must not be greater than 1.5 meters from the point of flame application.

17.4.3 “FT6” Fire Test

The FT6 test procedure is known as the Plenum Flame Test (published in CSA Standard C22.2 No. 0.3 Test Methods for Electrical Wires and Cables, para 4.11.6).

Designations

The markings for wires and cables meeting the flame spread requirements of the National Building Code of Canada (without additional fire protection) are:

FT1—*Wires and cables that are suitable for installation in buildings of combustible construction; and*

FT4—*Wires and cables that are suitable for installation in:*

- (a) buildings of noncombustible and combustible construction; and*
- (b) spaces between a ceiling and floor, or ceiling and roof, that may be used as a plenum in buildings of combustible or noncombustible construction.*

Wires and cables with combustible outer jackets or sheaths that do not meet the above classifications should be located in noncombustible raceways, masonry walls or concrete slabs.